

Caracteristici Principale

Gama de produse	Harmony XB4
Tip produs sau componenta	Cap și bază de montaj pentru potențiometru
Nume scurt al dispozitivului	ZB4
Material rama	Metal cromat
Diametrul de montaj	22 mm
Compatibilitate produs	Pentru utilizare cu ax Ø 6 mm
Vânzare în cantitate indivizibilă	1
Forma a capului unitatii de semnalizare	Rotund
Profil operator	Mâner striat, alb cu

Complementare

Greutate produs	0.08 kg
Rezistență la spălare cu presiune înaltă	7000000 Pa la 55 °C, distanța: 0.1 m
Grup principal	Potențiometer
Grup de produse	Potențiometer knurled knob
Culoarea marcajului	Alb

Mediu

Tratament protector	TH
Temperatura de depozitare	-40...70 °C
Temperatura ambiantă pentru utilizare	-25...70 °C
Clasa de protecție la electrocutare	Clasa I conformitate cu IEC 60536
Grad de protecție IP	IP66 conforming to IEC 60529
Grad de protecție NEMA	NEMA 4X NEMA 13
Grad de protecție IK	IK03 conformitate cu IEC 50102
Standarde	EN/IEC 60947-1 SR EN 60947-5-1 EN/IEC 60947-5-4 EN/IEC 60947-5-5 JIS C 4520 UL 508 CSA C22.2 No 14
Certificari produs	BV CSA DNV GL LROS (Lloyds register of shipping) RINA Listat de UL
Rezistența la vibrații	5 gn (f = 2...500 Hz) conformitate cu IEC 60068-2-6
Rezistența la socuri	30 gn (duration = 18 ms) for half sine wave acceleration conforming to IEC 60068-2-27 50 gn (duration = 11 ms) for half sine wave acceleration conforming to IEC 60068-2-27

Contractual warranty

Period	18 months
--------	-----------

Dimensions

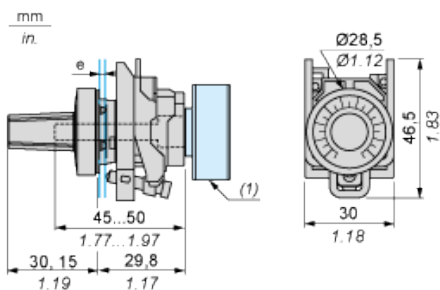

e: panel thickness: 1 to 6 mm / 0.04 to 0.24 in.

(1) Potentiometer not included

Pushbuttons, Switches and Pilot Lights for Printed Circuit Board Connection

Panel Cut-outs (Viewed from Installer's Side)

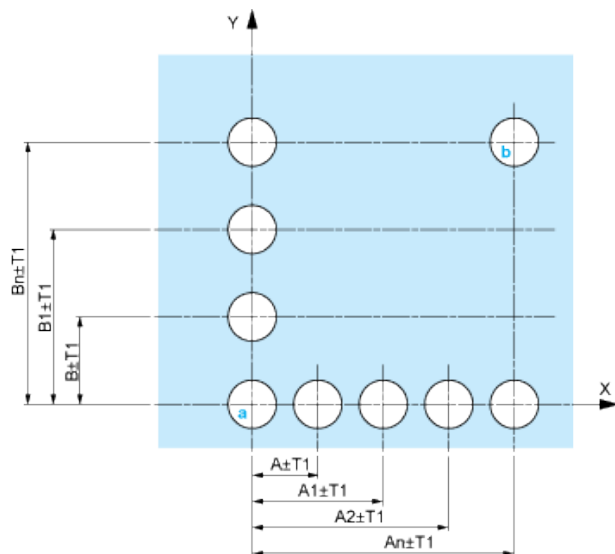

A: 30 mm min. / 1.18 in. min.

B: 40 mm min. / 1.57 in. min.

Printed Circuit Board Cut-outs (Viewed from Electrical Block Side)

Dimensions in mm

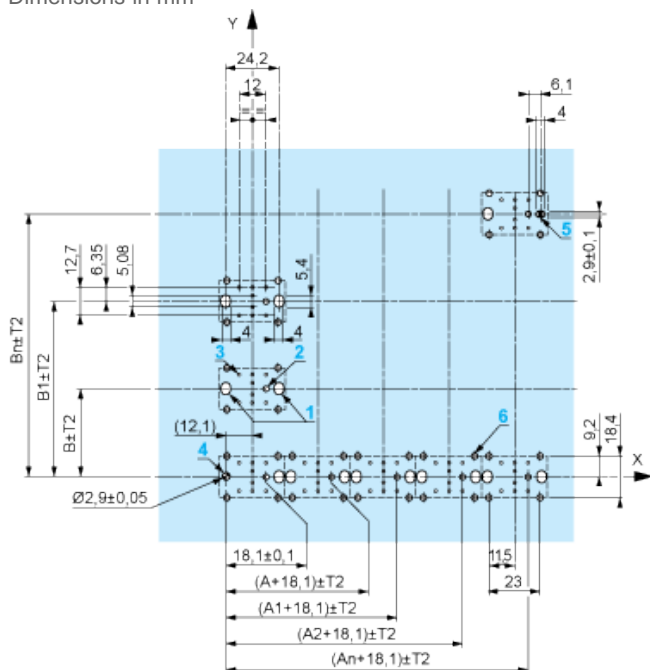

A: 30 mm min.

B: 40 mm min.

Dimensions in in.

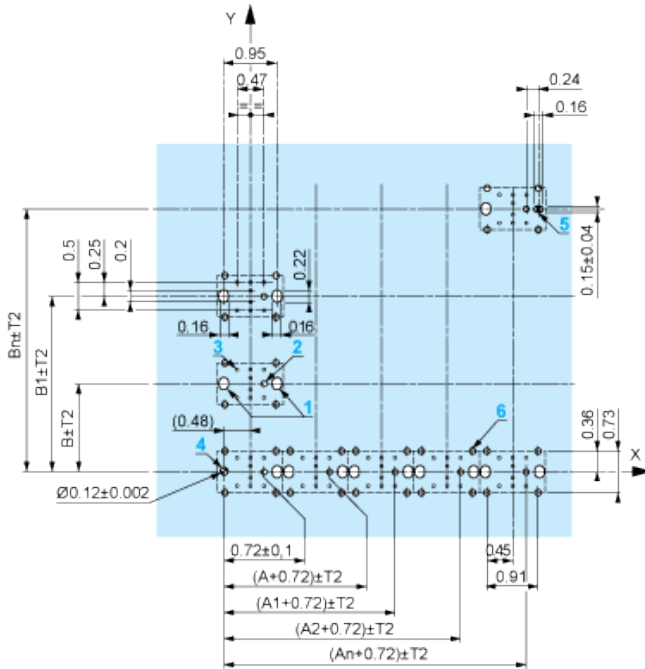

A: 1.18 in. min.

B: 1.57 in. min.

General Tolerances of the Panel and Printed Circuit Board

The cumulative tolerance must not exceed 0.3 mm / 0.012 in: $T1 + T2 = 0.3 \text{ mm max.}$

Installation Precautions

- Minimum thickness of circuit board: 1.6 mm / 0.06 in.
- Cut-out diameter: 22.4 mm \pm 0.1 / 0.88 in. \pm 0.004
- Orientation of body/fixing collar ZB4 BZ009: \pm 2°30' (excluding cut-outs marked **a** and **b**).
- Tightening torque of screws ZBZ 006: 0.6 N.m (5.3 lbf.in) max.
- Allow for one ZB4 BZ079 fixing collar/pillar and its fixing screws:
 - every 90 mm / 3.54 in. horizontally (X), and 120 mm / 4.72 in. vertically (Y).
 - with each selector switch head (ZB4 BD•, ZB4 BJ•, ZB4 BG•).

The fixing centers marked **a** and **b** are diagonally opposed and must align with those marked **4** and **5**.

$\frac{\text{mm}}{\text{in.}}$

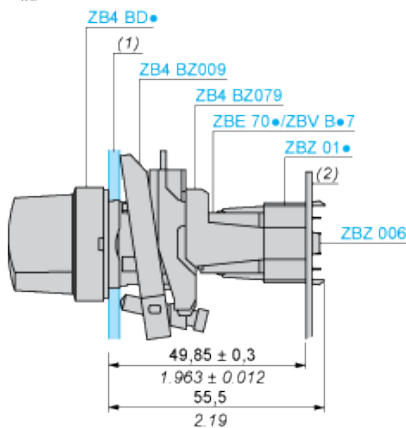

(1) Panel

(2) Printed circuit board

Mounting of Adapter (Socket) ZBZ 01•

- 1 2 elongated holes for ZBZ 006 screw access
- 2 1 hole \varnothing 2.4 mm \pm 0.05 / 0.09 in. \pm 0.002 for centring adapter ZBZ 01•
- 3 8 \times \varnothing 1.2 mm / 0.05 in. holes
- 4 1 hole \varnothing 2.9 mm \pm 0.05 / 0.11 in. \pm 0.002, for aligning the printed circuit board (with cut-out marked **a**)
- 5 1 elongated hole for aligning the printed circuit board (with cut-out marked **b**)

- 6 4 holes \varnothing 2.4 mm / 0.09 in. for clipping in adapter ZBZ 01•

Dimensions An + 18.1 relate to the \varnothing 2.4 mm \pm 0.05 / 0.09 in. \pm 0.002 holes for centring adapter ZBZ 01•.